

# Application of Artificial Muscles as Actuators in Engineering Design

Zhun Fan<sup>1</sup>, Kristoffer Raun<sup>1</sup>, Lars Hein<sup>2</sup>, Hans-Erik Kiil<sup>3</sup>

<sup>1</sup>Department of Mechanical Engineering, Technical University of Denmark, Lyngby, Denmark

<sup>2</sup>Institute of Product Development (IPU), Technical University of Denmark, Lyngby, Denmark

<sup>3</sup>Danfoss A/S, Norborg, Denmark

## Abstract

A new actuator technology based on ‘artificial muscle’ concept has emerged recently. Artificial muscles refer to a class of materials that can mimic part of properties found in human muscles. They have the potential to replace traditional actuators, e.g. electric motors in many applications. One example can be robot arm design for service robots. Utilization of artificial muscles to replace electric motor actuators can dramatically reduce the weight and noise, and have the possibility of significantly reducing the complexity of control. To apply them as actuators, it is important to investigate dynamic characteristics of the artificial muscles to be used in designing a system with requirements of dynamic behaviors. This paper attempts to measure several important dynamic characteristics of one type of artificial muscle – Electro Active Polymer (EAP). As a case study, a two level robot arm is designed and built up, with a closed loop control system actuated by the EAP being investigated.

*Keywords: artificial muscle, design, closed loop control system, robot arm design, Electro Active Polymer (EAP)*

## 1. Introduction

Artificial muscle is an emerging technique that has attracted much attention in recent years. Artificial muscle is based on polymer with many attractive characteristics – they are generally light weight, inexpensive, noiseless, fracture tolerant and pliable. They have higher power density and therefore can consume much less power. Furthermore, they can be configured into almost arbitrary shape and their properties can be tailored to suit a broad range of requirements [1].

The background of the work is that Danfoss A/S, a major Danish industrial company, has developed a new actuator technology based on the Electro Active Polymer (EAP) materials. Danfoss started its work on EAP in 1998 in a

collaboration project ARTMUS together with the Danish Polymer Centre at Resø, and the Department of Chemistry at DTU [4].

In spring 2006, a venture project called PolyPower was initiated at Danfoss to investigate the possibilities of scaling up production and design new actuators and applications based on EAP. Up to now, Danfoss has accomplished manufacturing actuators in an up-scaled laboratory level and is looking into larger-scale manufacturing and application possibilities.

The work reported in this paper is based on usage of flat 2-layer back-to-back ARTMUS actuator manufactured in the laboratory. There are two objectives in the work: one is to identify several dynamic properties of the actuator such as stiffness, damping, etc. The other is to demonstrate the performance of the EAP actuator by designing and building a two-level robot arm system actuated by EAP actuators.

The remainder of the paper is organized as the following: Section 2 will give a short introduction to different types of artificial muscle technology, in particular EAP. Section 3 explains the work of identifying dynamic properties of EAP actuator being used. Section 4 describes the design procedure for the two level robot arm system, with the final product also built up and demonstrated. The paper concludes with section 5 with some discussions for future improvements.

## 2. Types of Artificial Muscles

### 2.1 Comparison of Different Muscles

There are three main types of artificial muscles.

- SMA – Shape Memory Alloys
- EAC – Electro Active Ceramics
- EAP – Electro Active Polymers

In the table 1, the different technologies are compared with each other and also with human biological muscles in terms of some key properties.

**Table 1.** Comparison between three types of artificial muscle and human muscle [1][2]

Property	Human muscle	SMA	EAC	EAP
Actuation strain [%]	20% (max. 40%)	< 8%	Max. 0.3%	> 300%
Force [MPa]	0.1	200	40	25
Reaction speed	msec	msec to min	µsec to sec	µsec to min
Density [kg/m <sup>3</sup> ]	1037			960-1100
Power to mass [W kg <sup>-1</sup> ]	50 (max.200)	3500		Up to 3500
Drive voltage	-	5V	50-800V	Ionic: 1-7 V, Electronic: 10- 150V/µm
Consumed power	-	Watts	Watts	Milli-watts
Fracture toughness	High and can self repair	Resilient, elastic	Fragile	Resilient, elastic

It can be seen that all three artificial muscles have the potential of giving out very strong forces. However, the actuation strain differs a lot. The actuation strain of EAP is far superior to the other types. In particular, actuation strain of EAC is so small that it cannot really mimic the performance of the human muscle, and is therefore mostly used in micro-applications, e.g. piezoelectric actuators. In these areas, EAC has extra advantages of very fast reaction speed and very high force generation.

SMA can be applied well in the area of osteosynthesis; surgery involving joining and stabilizing the ends of a fractured bone by mechanical devices. Clinical considerations with regards to rejection of the implantation, as well as thoughts on dynamic material that can “grow” with the patient, are key issues. The downside of this actuator type for other types of applications, is the low efficiency in converting the electrical energy to mechanical work, as well as a poor recovery of the induced heating due to work.

The drive voltages also vary a lot - some muscles are driven at around 5 volts, and some at much higher voltage levels at the kilo volt range. It is notable to see that EAP consumes the least amount of power in the three types of artificial muscles. An important feature of the human muscle which is not possessed by other artificial muscle actuators today is its ability to self-repair.

## 2.2 EAP Actuators

EAP actuators are polymers that respond to electrical stimulation with either a size or shape change. The EAP's are divided into two major categories, the *Ionic* and the *Electronic*.

Comparison of the two categories is listed in the Table 2.

**Table 2.** Comparison of Ionic and Electronic EAP Actuators [2]

EAP Type	Advantages	Disadvantages
Electronic EAP	Operation in room conditions Fast response in milli-second range Holds strain under dc activation Relative large actuation forces	Requires high voltage in the kV area. Compromise between strain and stress Glass transition temperature is inadequate for low-temperature actuation tasks.
Ionic EAP	Produces large bending displacements Requires low voltage in the range 1-7 volts Bidirectional bending motion depending on voltage polarity	Except CP and CNT, Ionic EAP do not hold strain under dc voltage Slow response Bending EAP induce low actuation force Strict material tolerances to ensure uniform quality actuators

The Electronic EAP uses the Maxwell stress to generate a strain. When the electrodes are activated by DC-voltage, the Maxwell stress attracts the two electrodes of opposite charge, and squeezes the polymer in the middle, which makes the polymer to expand orthogonal to the applied pressure. The technology is in many ways similar to the capacitor-technology, for example, the electronic EAP holds strain as a capacitor stores capacitance. The downside of this technology is the requirement for high voltage in the kV range.

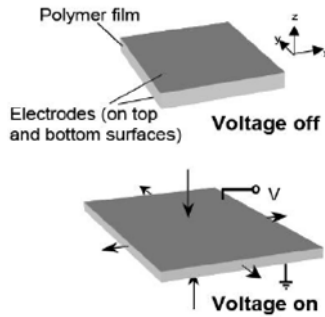

**Figure 1.** Applying voltage to the electrodes makes the electrostrictive forces to squeeze the elastomer [3]

Danfoss A/S has chosen one type of electronic EAP - the dielectric EAP actuator. Even though it requires high voltage in the kV range, the relative large actuation forces and a capability to hold strain under dc-activation, is of major concern.

### 3. Dynamic Properties of EAP Actuators

This paper uses experimental modal testing for identification of the dynamic properties of the EAP actuator as a function of the applied voltage in a given frequency range. The obtained dynamic properties can be used to create a mathematical model describing the EAP actuator, e.g. in a form of a rheological model which can be used to optimize the control of e.g. a robotic arm.

Experimental modal testing is a method to obtain stiffness and damping characteristics of a given object by analyzing its vibration responses in a given structure. One major technique used in modal analysis is based on shaker excitation. The vibration responses of the structure are measured using signal analysis and transformed into frequency response functions (FRFs) using Fast Fourier Transformation (FFT) techniques. The FRFs are used to extract modal parameters e.g. natural frequencies, stiffness and damping for the object.

#### 3.1 Measurement Setup

The test rig used in this work is shown in Figure 2. An exciter is installed on the left stand. A string is used to connect the exciter to the moving mass in the middle, and the other end of the moving mass is connected through artificial muscle, i.e. the flat 2-layer back-to-back ARTMUS actuator to the right stand. A major issue in this measurement setup is that very high voltage in the range of Kilo Volts is needed to activate the EAP actuator. To achieve this, a high voltage power supply with adjustable gain is developed and used in the measurement setup.

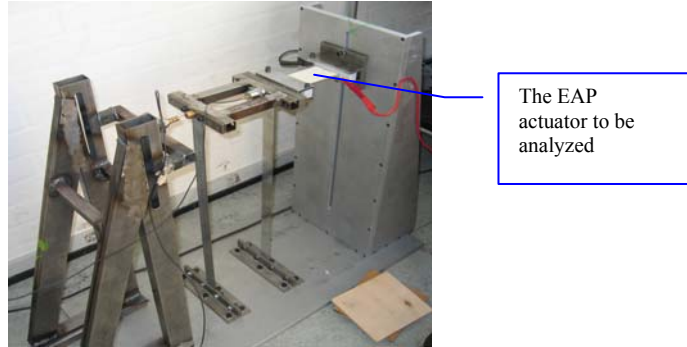

**Figure 2.** The test rig to measure dynamic properties of the artificial muscle – EAP actuator

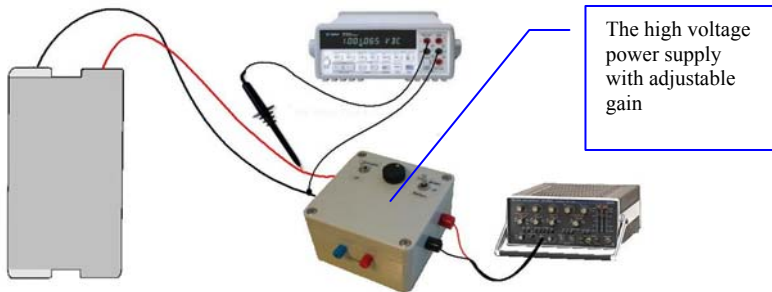

**Figure 3.** Measurement setup to determine voltage level applied to the EAP actuator

### 3.2 Measurement Results

The stiffness and damping as a function of voltage drive has been measured. The input of voltage drive to the EAP actuator ranges from 0 to 2500 volts with steps of 100 volt. The actuator was subject to a 8mm or 10% of prestrain. The results are shown in Figure 4 and Figure 5 respectively. It can be seen that the stiffness goes from 41N/m at 0V input drive to 42N/m at 1900V. At 2000V, the stiffness decreases rapidly. The damping is relatively constant up to 800V, and then dramatically increases from 0.17 N/m/s to 0.21 N/m/s at 1500V. It decreases sharply to around 0.17 N/m/s at 1600V, and increases again to 0.23 N/m/s at 2000V. The damping then decreases significantly above 2000V.

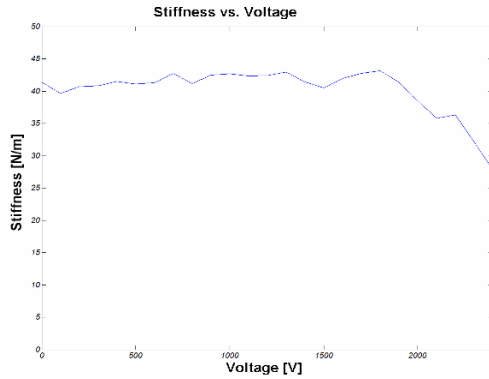

**Figure 4.** Measurement results of stiffness vs. voltage

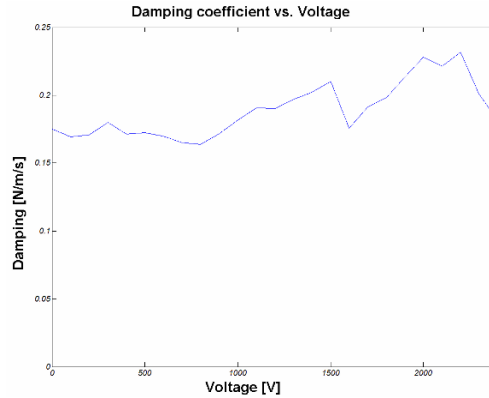

**Figure 5.** Measurement results of damping coefficient vs. voltage

The results show that the stiffness and damping of the EAP actuator cannot be considered constant under different voltage drives. This indicates that for more demanding e.g. high precision, or high speed applications driven by EAP actuators, a more complete, higher order rheological model needs to be developed to precisely reflect dynamic behaviors of EAP actuators. However, for less demanding applications, the current model can be considered sufficient.

## 4. Design of a Two Level Robot Arm Using EAP Actuators

### 4.1 Design Concept of the Robot Arm System

The idea of robot arm design stems from the concept shown in Figure 6, in which two EAP actuators are used to drive a revolute joint so that the upper arm can

rotate. Design of robot arm is chosen as an application also because for a more precise control of speed and position of the rotation, some dynamic characteristics of the driving EAP actuators need to be known.

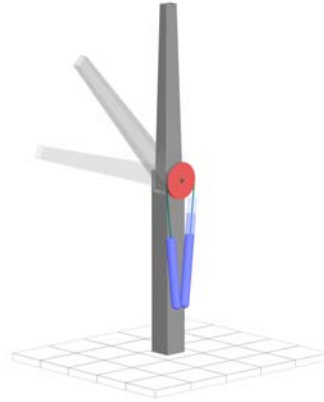

**Figure 6.** The concept of using two EAP actuators in parallel to drive a revolute joint of a robot arm

The final design concept utilized in this work is shown in Figure 7, in which four flat 2-layer back-to-back ARTMUS actuators are used to drive two level robot arms (second link and third link in Figure 7)

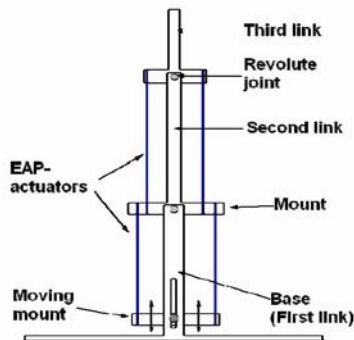
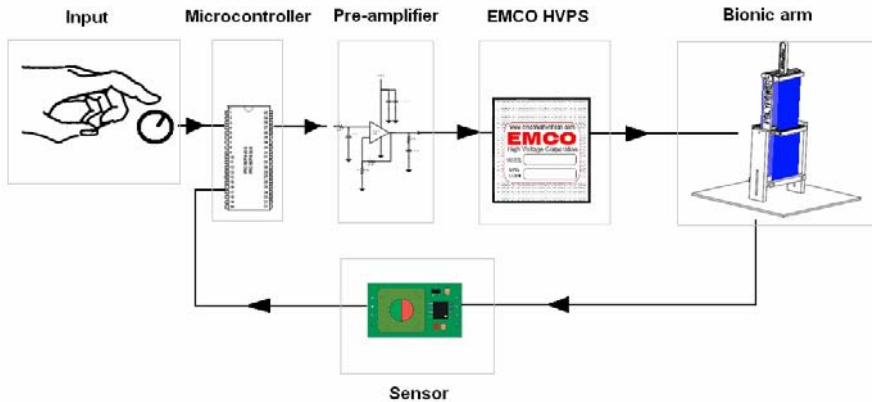

**Figure 7.** The design concept of two level robot arm actuated by 4 EAP actuators

## 4.2 Electronics to Control the Robot Arm

The electronics used to control the robot arm consists of a microcontroller, a power amplifier, a high voltage power supply, and a potentiometer sensor. The overview of the system is shown in Figure 8. It involves a microcontroller that can define the control algorithm. The microcontroller reads the difference between the target input and the actual output measured by the sensor, and calculates an output according to the control algorithm. The output signal is first pre-amplified by a pre-

amplifier, and then the amplified signal will be input to a High Voltage Power Supply (HVPS) so that a voltage drive in the range of Kilo Volts can be generated to drive the EAP actuators of the robot arm system. Figure 9 shows the actual electronics system to control the robot arm.



**Figure 8.** The overview of the closed loop control system for the robot arm



**Figure 9.** The actual electronics system to control the robot arm

### 4.3 Implementation of the Design Concept into a Physical Robot Arm System

The overall proof-of-concept system is built up based on the design concept described in the previous sections and is shown in Figure 11. When the robot arm system is activated, the two level arms can be rotated to both directions in two modes: 1) both arms can rotate in predefined frequencies or 2) both arms can rotate to angular positions defined by the user. Figure 10 shows a snapshot when the



robot arm is in action. It can be seen that the first-level arm and the second-level arm are rotating in different angles.

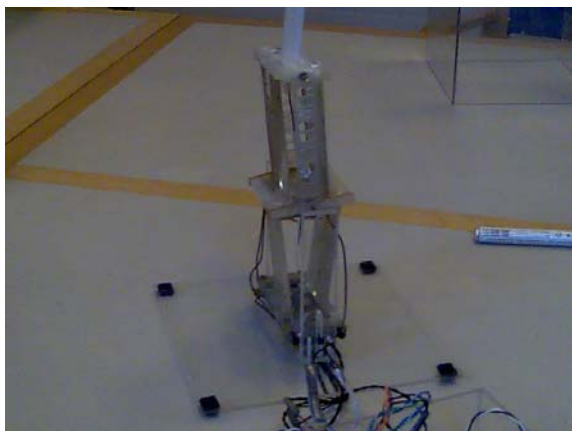

**Figure 10.** The robot arm in action

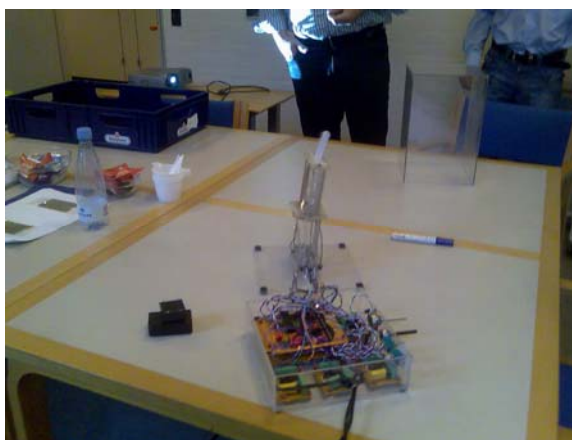

**Figure 11.** The overall experimental configuration of the robot arm system

## 5. Conclusions and Discussions

The paper reports a preliminary work of applying artificial muscles as actuators in engineering design, using a two level robot arm design as a case study. The work focuses on the usage of a type of electronic EAP actuator available to the authors of the work, but the principle is also applicable to other types of artificial muscles.

It is believed to be important to investigate dynamic characteristics of the artificial muscle to be used as actuators in designing a system with requirements of dynamic behaviours. The work studies the damping and stiffness of the investigated EAP actuator under a range of drive voltages. It also demonstrates the feasibility of using artificial muscle as actuators in a designed and built two level robot arm system.

The system at the current stage is still a proof of concept, with a number of unsolved issues to be further investigated. A higher order dynamic model can be used to study the transient response of the artificial muscle to external force. Another important task, for example, is to identify the system model of the artificial muscle with voltage drive as one of the inputs and force and stroke as outputs.

The potential application areas using artificial muscles are almost endless, and now we are only standing in a stage when the manufacturing technologies of artificial muscles can start to support some preliminary real world applications. Further investigation of the limitations of existing techniques and how they can be integrated in the engineering design of a larger variety of products is therefore very meaningful task and will be one of the next step research plans of the group.

## 6. References

- [1] Bar-Cohen Y., *Electroactive Polymers as Artificial Muscles – Reality, Potential, and Challenges*, second edition, SPIE EAPAD – Short Course, March 6 2005, San Diego, California
- [2] Bar-Cohen Y., *Electroactive Polymer (EAP) Actuators as Artificial Muscles – Reality, Potential, and Challenges*, second edition, SPIE – The International Society for Optical Engineering, Bellingham, Washington 98227-0010 USA
- [3] O'Halloran A, O'Malley F., *Materials and Technologies for Artificial Muscle: A Review for the Mechanical Muscle Project*. Department of Electronic Engineering, National University of Ireland Galway. Available online at [http://www.tcd.ie/bioengineering/documents/ChapterVII\\_000.pdf](http://www.tcd.ie/bioengineering/documents/ChapterVII_000.pdf)
- [4] Benslimane M. et al. *ARTMUS – Artificial Muscles*, Risø National Laboratory, The Technical University of Denmark, Danfoss A/S, December 30, 2001.